

My innovation We share

# Air conditioner

Air Conditioner User Manual

MODEL: BPD1500/C1

- Be sure to read this user manual carefully before using this product.
- Be sure to keep this manual safe so that you can refer to it at any time in the future (keep a backup).
- Please use it correctly on the basis of full understanding of the contents.
- Before using the product, please be sure to read the manual carefully
- Be sure to keep this manual properly so that you can access it at any time in the future.
- On the basis of fully understanding the content, please use it correctly.

---

# Contents

## /CONTENT

<b>1</b>	<b>Introduction to... ..</b>	<b>3</b>
1.1	Introduction.....	3
1.2	Product introduction... ..	3
1.3	The main standard... ..	4
<b>2</b>	<b>Product parameters... ..</b>	<b>4</b>
2.1	Technical parameters... ..	4
2.2	Installation diagram... ..	5
2.3	Opening figure... ..	6
<b>3</b>	<b>Preparation and installation... ..</b>	<b>6</b>
3.1	Unpacking and check... ..	6
3.2	Machinery installation... ..	7
3.3	Electrical installation... ..	7
<b>4</b>	<b>Product features... ..</b>	<b>8</b>
4.1	Refrigeration... ..	8
4.2	Heating... ..	8
4.3	Remote monitoring... ..	9
4.4	External fan gang... ..	9
<b>5</b>	<b>Display... ..</b>	<b>9</b>
5.1	Main interface display and buttons that.....	9
5.2	Menu structure... ..	10
5.3	According to... ..	11
5.4	Activate the self-check... ..	11
<b>6</b>	<b>Run... ..</b>	<b>11</b>
6.1	Run before the check... ..	11
6.2	Switched on... ..	12
<b>7</b>	<b>Fault analysis and processing... ..</b>	<b>12</b>
7.1	The alarm information... ..	12
7.2	Fault and processing... ..	12

---

**8 Preventive maintenance and... .. 13**

**1. Introduction..... .. 15**

1.1. Preface..... .. 15

1.2. Product introduction..... .. 15

1.3. Standards..... .. 16

**2. Product parameter..... .. 17**

2.1. Product technology parameters..... .. 17

2.2. Installation diagram..... .. 18

2.3. Cutting size..... .. 18

**3. Preparation and installation..... .. 19**

3.1 Removing the package and the package  
checking..... .. 19

3.2 Mechanical installation..... .. 19

3.3. Electrical installation..... .. 20

**4. Product function..... .. 21**

4.1. Cooling..... .. 21

4.2. Heating..... .. 21

4.3. Remote monitor..... .. 22

4.4. The control of external fan..... .. 22

**5. Display screen..... .. 23**

5.1. Display interface..... .. 23

5.2. Menu structures..... .. 23

5.3. Display..... .. 24

5.4. Start self-test..... .. 24

**6. Running..... .. 25**

6.1 Check before start running..... .. 25

6.2. Start running..... .. 25

**7. Faults and treatment..... .. 25**

7.1.Alarm information..... .. 25

7.2. Faults and Faults treatment..... .. 26

**8. Maintenance..... .. 27**

# 1 The Intro

## 1.1 前言

This manual describes the installation, operation, function description, and periodic maintenance of the integrated air conditioner. Be sure to read it carefully and follow the precautions before using it.

Note: Any operation on this product must be carried out by a professional technician.

## 1.2 产品介绍

This air conditioner is a self-developed product for cooling the cabin body, which is suitable for the applications where the internal heat of the cabin body is large, the internal electronic equipment is sensitive to the ambient temperature, and the inside and outside need to be completely isolated. This product has a full range of functions, with high reliability, simple installation, can work after power, no need for complex debugging and so on.

The fan circulating in the air conditioner inhales hot air from the upper part, so that the air continues to exchange heat through the fins of the evaporator, and the air that becomes cold after the heat release is discharged from the lower part of the air conditioner and sent to the cabin. In this way, the air in the cabin constantly circulates to achieve the purpose of reducing the temperature. At the same time, the external circulation fan draws the cold air from the lower part of the outside world, and the hot air is discharged from the upper part of the air conditioner after heat exchange.

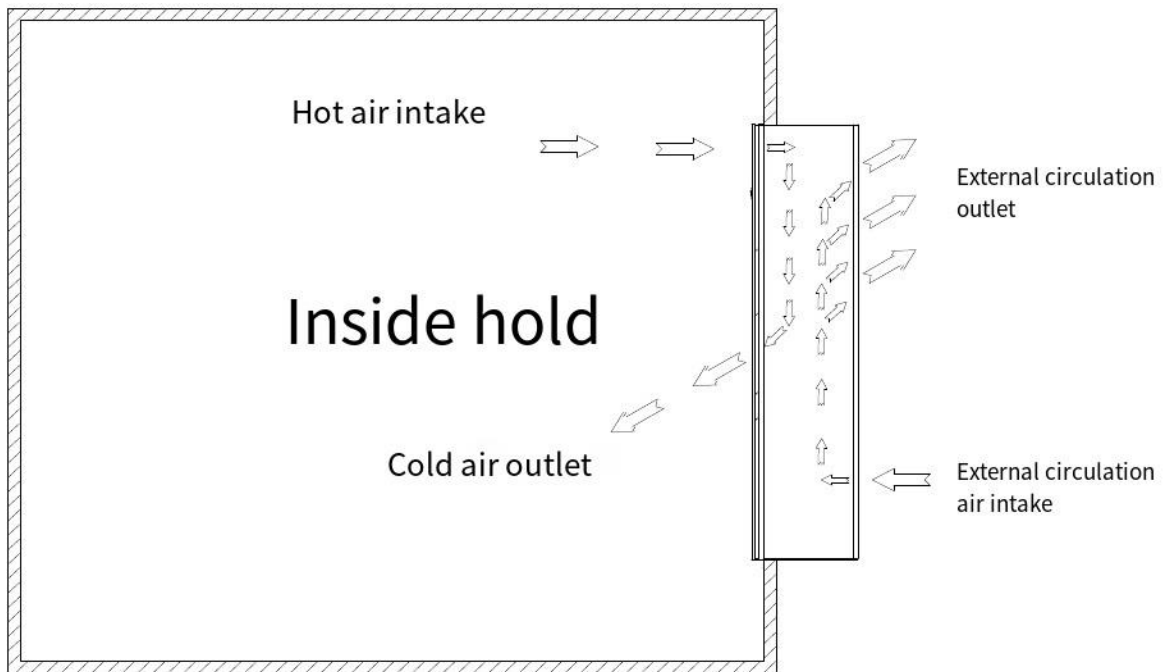

工作原理图

### 1.3 符合的主要标准

Serial number	Standard number	Standard name
01	GB 4208	Case protection class
02	GB/T 4857.5、9、10、11、16	Basic test of transport packaging
03	GB/T 2423.1、2、3、8、10、17、38	Environmental testing of electrical and electronic products
04	GB9254-1998	Limits and measurement methods for radio disturbance of information technology equipment
05	GJB150-86	Environmental test methods for military equipment
06	GB/T17626.8	Electromagnetic compatibility test and measurement technology power frequency magnetic field immunity test
07	YD/T 2768-2014	Temperature control equipment for communication outdoor computer rooms - Part 1: Embedded temperature control equipment
08	CE	Third party certification

## 2 Product parameters

### 2.1 技术参数

type	Name	Units	Parameters
Dimensions and mounting	Overall dimensions (height * width * depth)	mm	746 * 446 * 200
	Dimensions including flange (H * W * D)	mm	784 * 484 * 200
	Weight	Kg	24
	Installation method	Recessed mount	
	Mounting environment	Outdoors	
Environment and Conservation	Working ambient temperature	°C	-40 to +55
	Noise	dB(A)	65
	Longevity	Years	> 10

	Class of protection	IP55	
	refrigerant	R134a	
	RoHS certification	yes	
Performance	Power range	42-58V	
	Cooling capacity (L35/L35)	w	1500
	Rated power (L35/L35)	w	430
	Rated current (L35/L35)	A	9.0
	Maximum operating current	A	13.4
	Add heat (optional)	w	500
	Circulating air volume	m/h	320

## 2.2 installation diagram

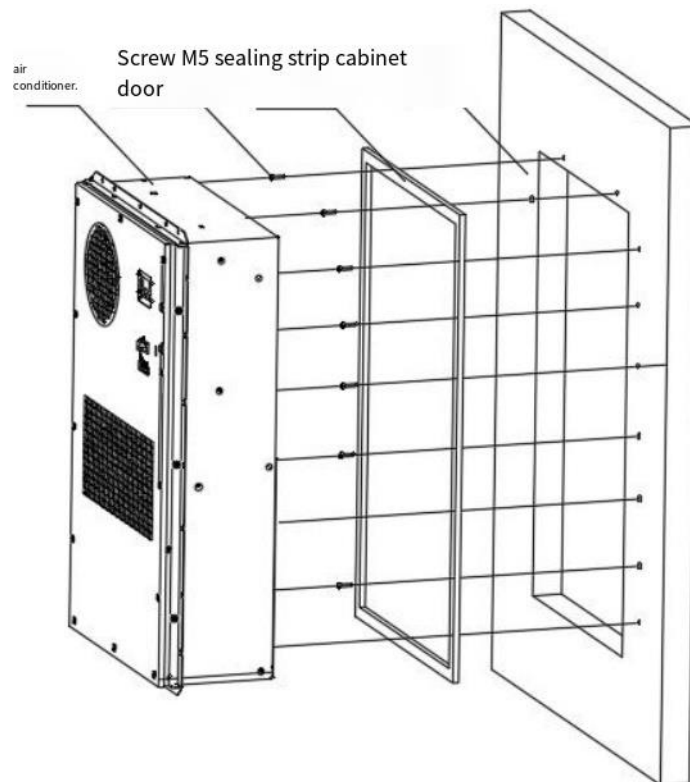

Note: The installation diagram is for reference, and the installation plan should be determined according to the actual use environment.

## 2.3 opening diagram

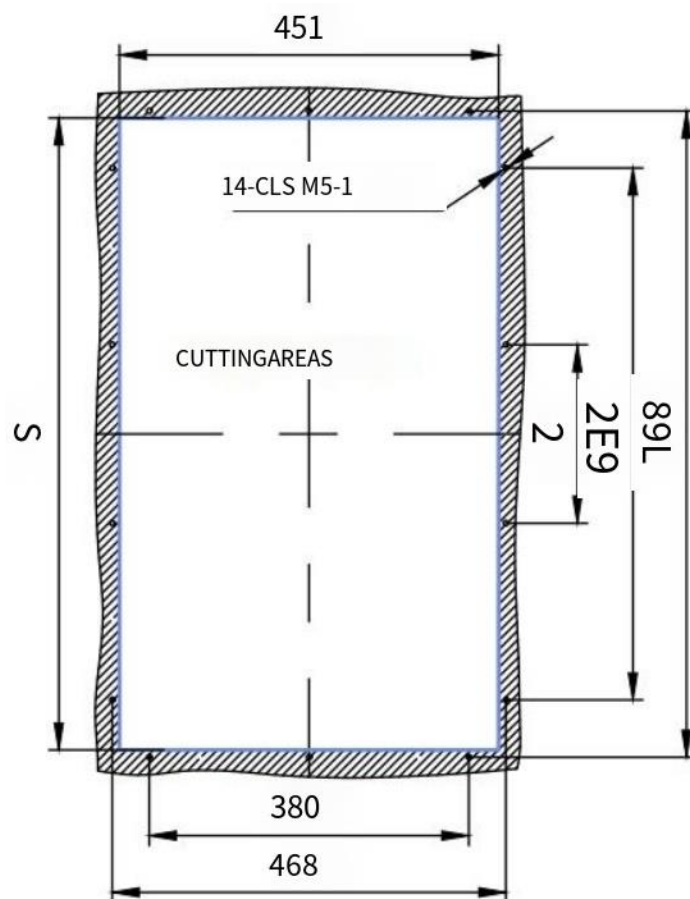

## 3 Preparation and installation

### 3.1 拆包及检查

1. Prepare tools for unpacking, such as blades and scissors, and wear protective gloves.
2. Remove the wrapping film and packing tape, remove the paper packaging, and take out the air conditioner.
3. Check the packing list and accessory bag in the packing box to confirm whether the air conditioner model in the packing box meets the requirements.

#### Attention:

1. After removing the packaging, make sure that the air conditioner is placed upright, not flat or upside down.
2. After the package is removed, check the appearance of the air conditioner for damage or oil stains. If the appearance of the air conditioner is obviously deformed or stained by oil, please contact the manufacturer in time.
3. If the product is not installed immediately or needs to be transferred to other areas, please package the air conditioner again after inspection.
4. It is recommended to recycle the packaging materials after removal.

## 3.2 Mechanical installation

Installation tool: Phillips screwdriver

Installation steps:

- 1) According to the hole size diagram, select the position on the cabin body, cut the shadow part area, and punch the installation hole.
- 2) Close the air conditioner flange to the door panel of the cabin body, and reliably fix the air conditioner on the mounting surface of the cabin body with M5 mounting screws.
- 3) Check whether the air conditioner is installed horizontally and reliably.

Be aware of:

Check whether the air conditioner drains smoothly to prevent blockage of the air conditioner drains.

When determining the position of installation openings on the cabin body, ensure that the air conditioner is well ventilated around the inlet and outlet should be kept at a distance of more than 150mm from the equipment in the cabin; otherwise, it may cause short circuit of the return air and poor cooling effect.

When handling or moving the air conditioner, handle with care to avoid collision and scratching the surface spraying of the equipment;

## 3.3 Electrical installation

(1) Power input port

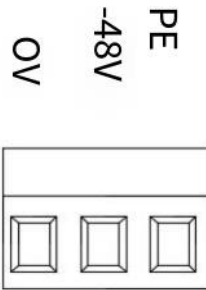

type	Corresponding port	Definition
Power supply	OV	Power supply plus
	-48V	Mains negative
	PE	Ground wire

(2) Alarm output and signal input ports

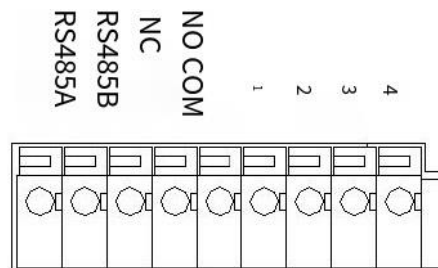

type	Corresponding port	Definition
------	--------------------	------------

RS485A communication interface	RS485A	Upper computer monitoring interface
RS485B communication interface	RS485B	Upper computer monitoring interface
Dry contact output NC contact	NC	Normally closed (closed when no alarm is generated)
Dry contact outputs COM contacts	COM	Common end
Dry contact output NO contact	NO	Normally open (disconnect when no alarm is generated)
Hydrogen exhaust/emergency fan dry contact output NO contact (optional)	1	Hydrogen exhaust/emergency fan dry contact output NO
Hydrogen exhaust/emergency fan dry contact output COM contact (optional)	2	Hydrogen exhaust/emergency fan dry contact output COM

### (3) Hydrogen exhaust/emergency fan connection

Maximum capacity of dry contact: AC fan: 2A/ 220VAC DC fan: 1.5A/60VDC (optional)

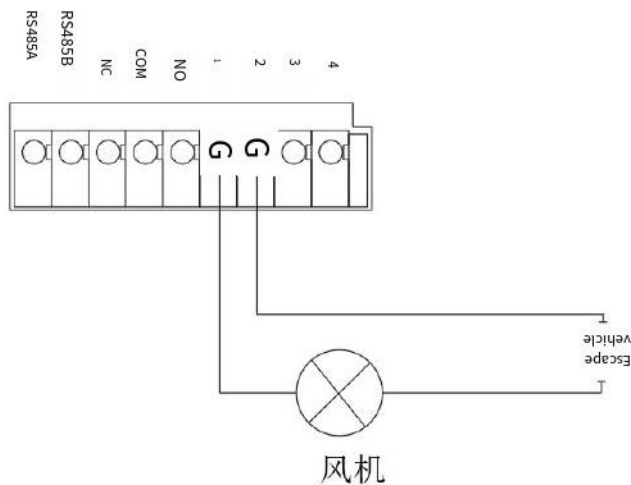

## 4 Product Features

### 4.1 refrigeration

When the temperature inside the cabin body is higher than the opening temperature of the refrigeration, the air conditioner begins to cool; When the temperature in the cabin body is lower than the cooling stop temperature, the air conditioning stops

Cold.

Parameter setting point

argument	Default values	Setting Range	Units	cooling stop temperature = cooling start temperature - cooling return difference temperature
Refrigeration opening temperature	32	[20 ~ 50]	°C	
Cooling return difference temperature	5	[3 ~ 15]	°C	

### 4.2 heat

When the temperature inside the cabin body is lower than the heating opening temperature, the air conditioning starts to heat up; When the temperature in the cabin body is higher than the heating stop temperature, the air conditioning stops adding

Heat.

Parameter setting point

argument	Default values	Setting Range	Units	Remarks
Heat on temperature	5	[to 30 ~ 50]	°C	Heating stop temperature = heating start temperature + heating return difference temperature
Heating return difference temperature	10	[3 ~ 15]	°C	

### 4.3 Remote monitoring

The air conditioner is equipped with the RS485 communication port for communication with the host computer. Alternatively, you can view the operating status of the air conditioner and change its operating parameters directly through the display screen.

### 4.4 External fan linkage

According to the optional requirements, the external fan (hydrogen exhaust/emergency fan) can automatically realize the functions of circulating hydrogen exhaust and emergency ventilation.

Hydrogen exhaust function: When the hydrogen exhaust cycle arrives, the air conditioner outputs the hydrogen exhaust fan by default, and the control switch is closed.

Hydrogen discharge function parameters

argument	Default values	Setting Range	Units
Hydrogen discharge cycle	24	[0 ~ 72]	h
Hydrogen discharge duration	5	[0 ~ 10]	Min

Emergency function: When the temperature in the cabin is greater than or equal to the emergency fan opening temperature, the emergency fan will open; When the temperature in the cabin is less than or equal to the emergency fan stop temperature

When, the emergency fan shuts down.

Emergency function parameters

argument	Default values	Setting Range	Units
Emergency fan opening temperature	45	[28 ~ 50]	°C
Emergency fan stop temperature	42	[25 ~ 50]	°C

## 5 display

### 5.1 Home screen display and button description

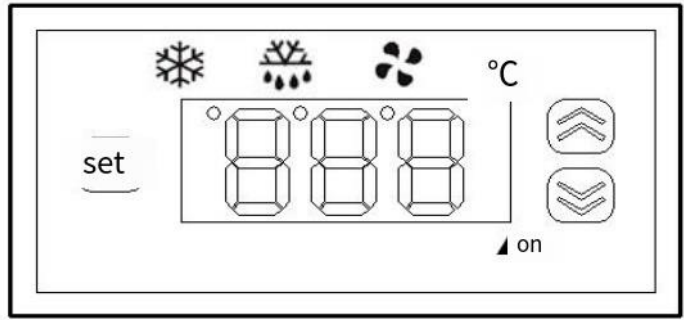

Serial number	ICONS	Features	Function Description
1		Refrigeration	Indicates that the air conditioner is in cooling condition
2		Heating	Indicates that the air conditioner is heated
3		Air supply	Indicates that the air conditioner is in supply mode
4		Confirm key	Confirm the function selection and parameter setting
5		Rise key	Add value or select previous record/menu
6		Drop key	Reduce the value or select the next record/menu

## 5.2 Menu structure

Press or to select an **C-P EAA S-P** function interface; Wait 5 s, it will return

The home screen is displayed.

**C-P** Parameter view. Press or , T01, T02, T03, T04, etc. Wait 2 seconds when the above code is displayed

The value of the temperature sensor can be displayed.

: View **EAA** The display displays alarm content in a region. If multiple fault alarms occur, the display displays the alarm information in sequence.

**S-P** Parameter Settings. Press under rface to perform numeric or to modify the value; After the value is modified as needed

Save the value, and automatically return to the previous level menu. In the process of setting parameters, the

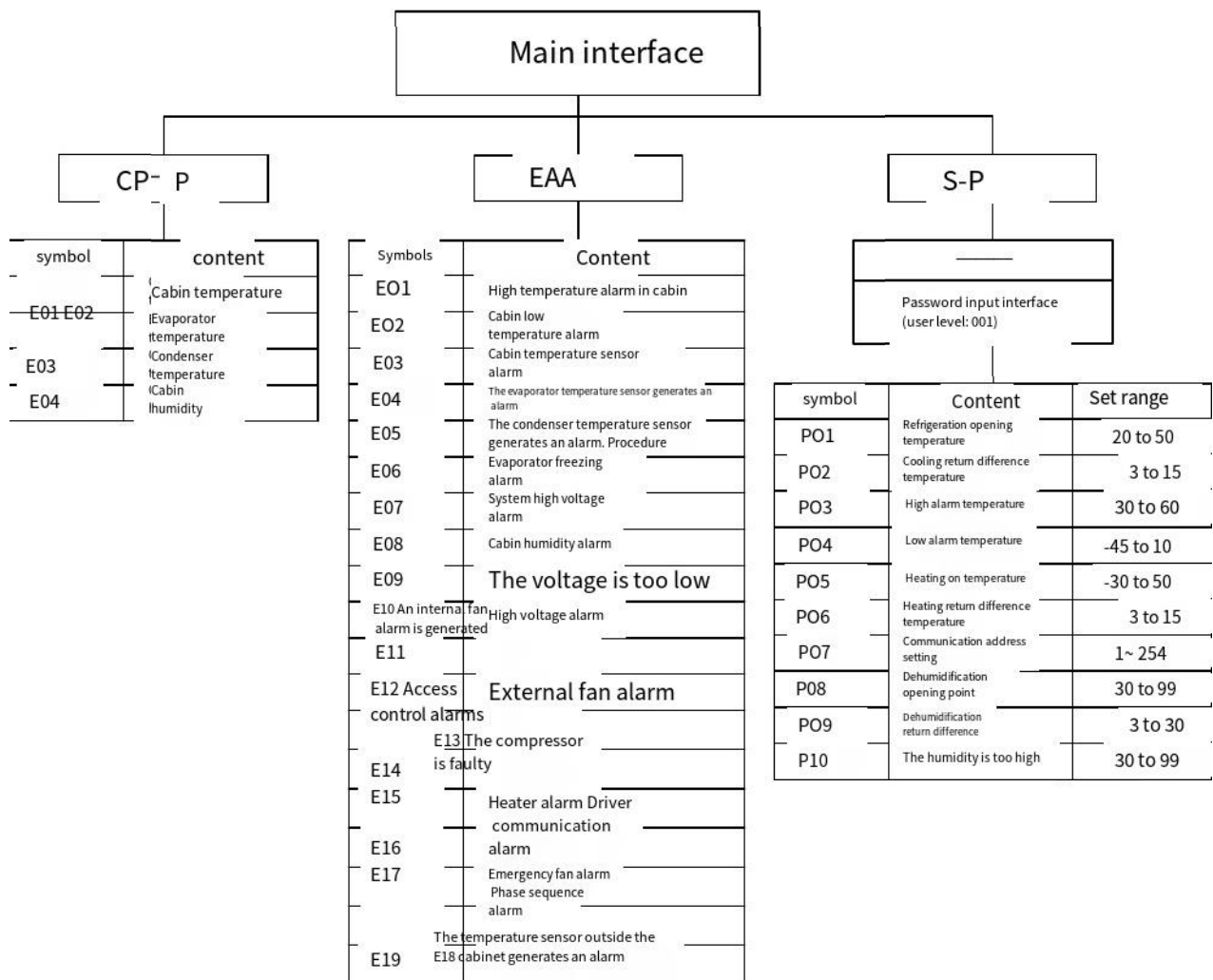

### 5.3 显示

In the running state, 8.8.8 of the main interface displays the real-time cabin temperature in the unit of ° C. After starting up, in any interface, if there is no keyboard operation for 20 seconds, it will automatically return to the main interface.

### 5.4 激活自检

In the running state, press and hold **SET** to activate the self-test function

During the self-test, the screen will display fully for 1S at the beginning, then the cabin temperature will be displayed normally, and the startup icon will blink.

## 6 Run

### 6.1 运行前检查

- 1) There is no obvious barrier near the inlet and outlet of the inner and outer circulation of the air conditioner.
- 2) The input power supply and other signal cables have been reliably connected, and the wiring is correct.

3) Check whether the voltage and frequency meet the requirements of the air conditioner.

4) The fan can rotate freely and smoothly without any sound.

## 6.2 开机运行

1) After the air conditioner is powered on, the internal fan starts to operate and the whole machine enters the compressor protection function. 3 minutes later, if the internal circulation temperature reaches the operating conditions, the refrigeration system runs.

2) The operating parameters have been set by default, and it can be confirmed that they are normal after operation; If you need to change the parameters, please refer to section 5.

## 7 Fault analysis and handling

### 7.1 告警信息

type	Trigger Conditions	Reset mode	Dry contact upload
High temperature alarm	The temperature in the cabin is higher than the set value	Auto	
Low temperature alarm	The temperature in the cabin is below the set value	Yes Auto	no
Cabin temperature sensor alarm	The cabin temperature sensor is faulty. The circuit of the sensor is short-circuited or disconnected	Auto	
Evaporator temperature sensor alarm	The evaporator temperature sensor is faulty. The sensor circuit is short or open	Yes Auto	no
Condenser temperature sensor alarms	The condenser temperature sensor is faulty. The sensor circuit is short-circuited or disconnected	Auto Auto not	
Evaporator freezing alarm	The evaporator temperature is lower than 0 ° C		
System High voltage alarm	The system pressure is greater than the set value	No Auto	no
Power off alarm	There is no power input to the control board	Auto	is

### 7.2 故障与处理

Fault type	Possible causes	Troubleshooting
Temperature sensor failure	Poor sensor connection	Check the sensor wire connection and reconnect it
	Damaged sensor	Replacing the sensor
High temperature alarm	The condenser or evaporator is dirty and blocked	Clean the condenser
	The cooling capacity of the air conditioner is insufficient	Consult a professional
System high pressure alarm	The temperature setting is inappropriate	Measure the temperature and reset the high temperature value to clean the condenser
	The condenser or evaporator is dirty and blocked	Clean the condenser
	The external circulation fan is faulty	Replace the external circulation fan
	False alarm from condenser temperature sensor	Replace the condenser temperature sensor

Freezing of evaporator	The internal circulating air is blocked	Check for the presence of occlusions and remove them
	<b>Internal circulation fan failure</b>	<b>Repair/replace the internal circulation fan</b>
	Refrigeration system cannot be turned off	Check that the cooling off condition is met without stopping the cooling. If yes, <b>Notify the manufacturer for treatment</b>
	Evaporator temperature sensor false alarm	<b>Replace the evaporator temperature sensor</b>
Compressor not running	<b>No refrigeration required</b>	<b>Check if refrigeration is required</b>
	<b>Be protected at 3 minute intervals</b>	<b>Check if it is protected</b>
	The compressor cable is improperly connected	<b>Check the sensor wire connection and reconnect it</b>
	The compressor protection switch or motor is damaged	If the compressor protection switch is intact, replace the compressor protection switch; If motor is damaged, replace the compressor
The internal circulation fan is not running	The internal circulation fan is faulty	<b>Replace the inner circulation fan</b>
	The inner circulating fan cable is improperly connected	<b>Check the sensor wire connection and reconnect it</b>
	<b>The fan is stuck</b>	<b>Check whether any foreign matter is stuck in the fan</b>
The external circulation fan is not running	The external circulation fan is faulty	<b>Replace the external circulation fan</b>
	The opening condition has not been reached	<b>Check that the opening condition is met</b>
	The inner circulating fan cable is improperly connected	<b>Check the connection of the outer circulating fan line and reconnect it</b>
	<b>The fan is stuck</b>	<b>Check for foreign objects that are stuck in the fan</b>
Fan noise	Fan blades are broken or bearings are chafed	<b>Replace the fan</b>
	Fan blades interfere with other materials	<b>Check and re-secure</b>
Heater not running	<b>Heater malfunctioning</b>	<b>Replace the heater</b>
	Heater wire is not connected properly	<b>Check the heater wire connection and reconnect it</b>
	Turn on condition not reached	<b>Check that the opening condition is met</b>

## 8 Care and maintenance

Regular maintenance of the air conditioner can maintain the good use effect and normal life of the air conditioner, mainly should do the following work:

Serial number	Inspection/Maintenance	Cycles
1	Check for an alarm prompt	June
2	Check that the fan is working properly	June
3	Check that the compressor is working properly	June
4	There is no obvious abnormal noise or jitter	June

---

5	Clean the air conditioner inlet and outlet grille	June
6	Clean the surface of the heat exchanger	1 year
7	Check whether the power cord and communication cable of the cabin air conditioner are normal	1 year

---

# 1. Introduction

## 1.1. Preface

This manual introduces the guide for the installation, operation, function and routine maintenance of the integrated air conditioner. Please read carefully the manual before using and follow the usage and note.

Note: All the operations of this product shall be performed by professional engineers.

## 1.2. Product introduction

The air conditioner is one kind of refrigeration product self-developed for cabin. It is applicable in the place where the cabin internal heat is very large, the internal electronic equipment is sensitive to the environment temperature and which should be isolated internally and externally completely. This product has multiple functions, high reliability, and has the feature that it can start to work without complex debugging after powering.

The fan in the internal cycle air path absorbs the hot air from the upside to make air heat exchange by evaporator fins, and sends the cooled air from the downside of the air conditioner. By so, the air in cabin can cycle to achieve the purpose of lowering the temperature. Meanwhile, The fan in the external cycle air path absorbs the external cold air from the downside, and discharges the hot air from the upside after heat exchange.

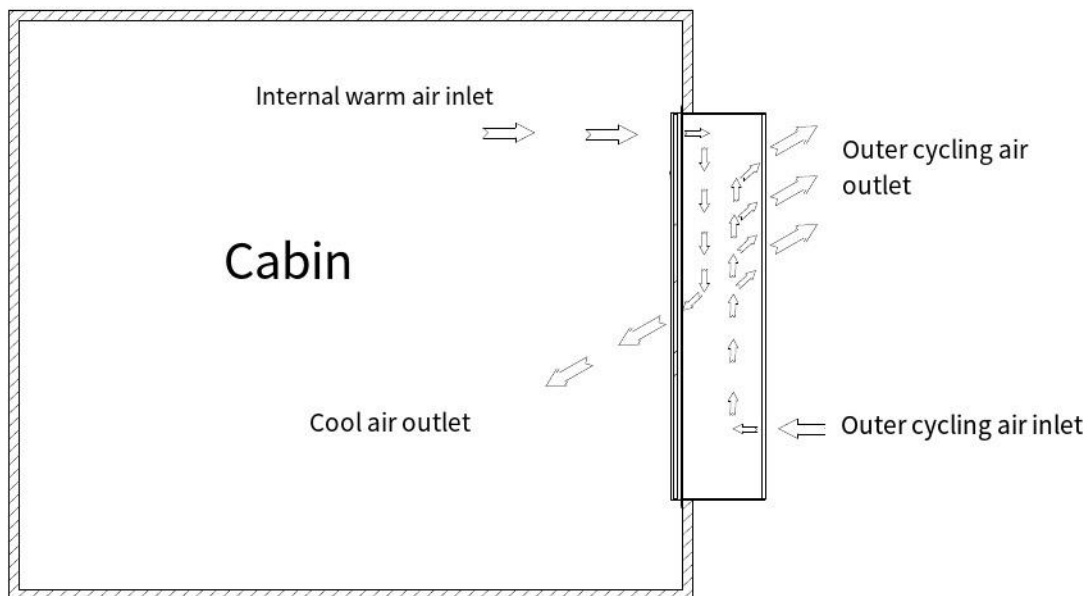

### 1.3. Standards

NO.	Standard No.	Standard Name
01	GB 4208	Enclosure Protection Class
02	GB/T 4857.5、9、10、11、16	Packaging-Basic tests for transport packages
03	GB/T 2423.1、2、3、8、10、17、38	Electrical and electronic products environmental test
04	GB9254-1998	Information technology equipment-Radio disturbance characteristics-Limits and methods of measurement
05	GJB150-86	Environmental test methods for military equipments
06	GB/T17626.8	Electromagnetic compatibility-Testing and measurement techniques--Power frequency magnetic field immunity test
07	YD/T 2768-2014	The temperature controlling devices for Communication outdoor room 1st parts: Embedded temperature controlling devices
08	EN 55022:2006+A1:2007	Conducted Emission and radiation test
09	EN 61000-3-2:2006+A2:2009	Harmonic Current
10	EN 61000-3-3:2008	Voltage Fluctuation and Flicker
11	EN 61000-4-2:2009	ESD
12	EN 61000-4-3:2006	Radiation disturbance Immunity Test
13	EN 61000-4-4:2004	Electrical Fast Transient Burst
14	EN 61000-4-5:2006	Surge
15	EN 61000-4-6:2009	Conduction disturbance Immunity Test Voltage dips and short interruptions
16	EN 61000-4-11:2004	

## 2. Product parameter

### 2.1. Product technology parameters

Item	Name	Unit	Parameter
Dimension and installation	Body outline dimension (height*width* depth)	mm	750 * 450 * 200
	Outline dimension including flange(height*width* depth)	mm	784 * 484 * 200
	Weight	Kg	24
	Installation method	Embedding slightly	
	Installation method	Outdoor	
Environment and protection	Working environment temperature	°C	-40 to +55
	Noise	dB(A)	65
	Life expectancy	Years	> 10
	IP grade	IP55	
	Refrigerant	R134a	
	ROHS certification	yes	
Performance	Input voltage range	48V	
	Refrigerating capacity(L35/L35)	W	1500
	Rated Refrigerating input power(L35/L35)	W	430
	Rated Refrigerating current (L35/L35)	A	9.0
	Maximum Refrigerating current	A	13.4
	Heat capacity (optional)	W	500
	Air Volume of Inner Circulation	m3/h	320

## 2.2. Installation diagram

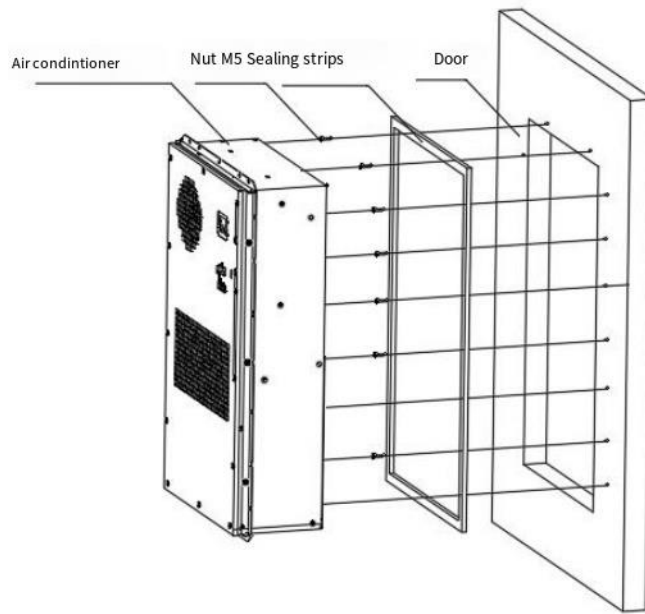

Note: the installation diagram is just for reference, the specific installation scheme should be determined according to the environment of the actual usage.

## 2.3. Cutting size

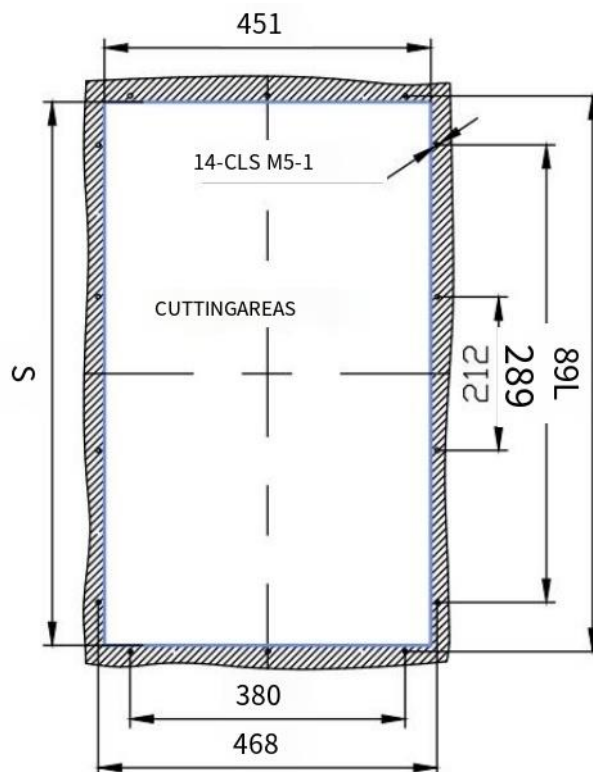

---

## 3. Preparation and installation

### 3.1 Removing package and checking

1. Please prepare installation tools: knife and scissors, and wear protective gloves.
2. Please remove wrapping film and packing belt, then remove the carton, take out the air conditioner.
3. Please check the attachment list and accessory bags in the carton, check whether the air conditioner model is right .

Notes:

1. After removing the outer package, please make sure that the air conditioner is placed upright , and not placed horizontally or upside down.
2. After removing the outer package, please check carefully whether the appearance of the air conditioner is damaged or oil polluted, if the appearance of the air conditioner has obvious deformation or oil stain, please contact the manufacturer in time.
3. If there is no need to install the product immediately or it needs to be transported to other place, please repack the air conditioner after the checking.
4. It is recommended to recycle the unpacking materials.

### 3.2. Mechanical installation

Installation tool: Phillips screwdriver

Installation Steps:

- 1) Choose cut location on the cabin according to the holing diagram, remove the shadow area and make the installation hole.
- 2) Make air conditioner flange close to cabin door, Fix the air conditioner on the installation surface of the cabin firmly with M5 screws.
- 3) Check whether air conditioner is installed levelly and firmly.

Notes:

- 1) Check whether air conditioner drainage loop is smooth, in case that drainage is blocked.
- 2) When determine the location of the installation hole in the cabin, you should avoid the inlet and outlet air ports inside the cabin are not blocked by any components inside the cabin, and the two should be kept a horizontal distance of more than 150mm; otherwise, it is prone to lead to r short circuit of the return air, and poor cooling effect, etc.;
- 3) carrying or moving the air conditioner should be careful to avoid colliding it and scratching

its surface coating;

### 3.3. Electrical installation

#### (1) Power input port

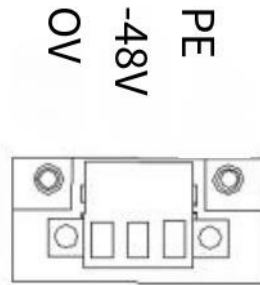

Item	Port	Definition
Power supply	OV	power input +
	-48v	power input
	PE	Earth line

#### (2) Alarm output and signal input port

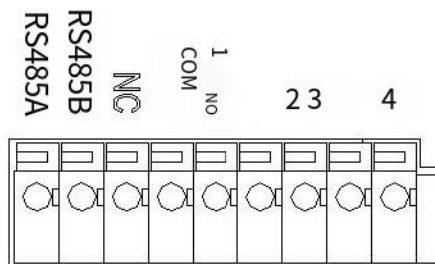

Item	Port	Definition
- RS485 communication interface	RS485A	RS485 communication ports (+)
- RS485 communication interface	RS485B	RS485 communication ports (-)
The public alarm dry nod (NO)	NO	It is normally open if no alarm
The public alarm dry nod (COM)	COM	common port
The public alarm dry nod (NC)	NC	It is normally close if no alarm
Hydrogen discharge /emergency fan dry contact (NO) (Optional)	1	It is normally open if no output

Hydrogen discharge / emergency fan dry contact COM (Optional)

2	Hydrogen discharge /emergency fan dry contact COM
---	---

(3) Hydrogen discharge/emergency fan wiring

The maximum capacity of the dry contact is: AC fan: 2A/220VAC, DC fan: 1.5A/60VDC (optional)

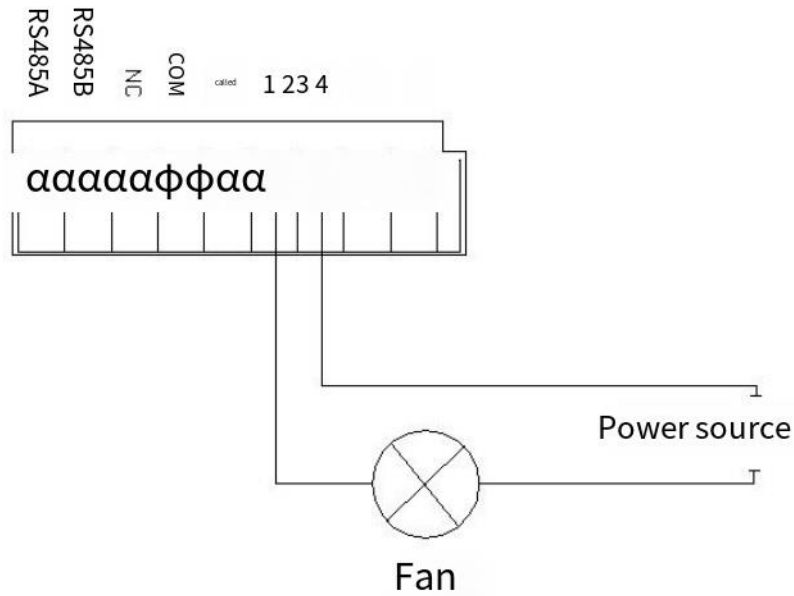

## 4. Product function

### 4.1. Cooling

When the temperature inside cabin is higher than refrigeration starting temperature, it starts refrigerating; when the temperature inside cabin is lower than refrigeration stopping temperature, it stops refrigerating.

User parameter setting point

Parameter	Default value	Setting range	Unit	Note
Refrigeration starting temperature	32	[20 ~ 50]	°C	Refrigeration stopping temperature =Refrigeration starting temperature
Refrigeration return difference	5	[3 ~ 15]	°C	

### 4.2. Heating

When the temperature inside cabin is lower than heating starting temperature, it starts heating; when the temperature inside cabin is higher than heating stopping temperature, it stops heating.

User parameter setting point

Parameter	Default value	Setting range	Unit	Note
Heating starting temperature	5	[to 30 ~ 50]	°C	Heating stopping temperature= Heating starting temperature+ Heating return difference
Heating return difference	10	[3 ~ 15]	°C	

### 4.3. Remote monitor

The Air conditioner has an RS485 communication interface supporting the MODBUS-RTU communication protocol. The air conditioner communicates with the upper monitor through the RS485 communication interface. Or users can check the air conditioner's running state by viewing the display screen directly and change its running parameters.

### 4.4. The control of external fan

According to the optional requirement, the external fan (Hydrogen discharge / emergency fan) automatically realizes cycle hydrogen discharging and emergency ventilation function.

Hydrogen discharge function(Optional) : When hydrogen discharge cycle comes, air conditioner start the hydrogen discharge fan, the control switch closes.

hydrogen discharging function

parameter	Default value	Setting range	Unit
cycle	24	[0 ~ 72]	h
discharging time	5	[0 ~ 10]	Min

Emergency ventilation function (Optional): When the temperature inside cabinet is higher than Emergency ventilation starting temperature, emergency ventilation fans run; when the temperature inside cabinet is lower than Emergency ventilation stopping temperature, emergency ventilation fans stop.

Emergency ventilation function

parameter	Default value	Setting range	Unit
starting temperature	45	[50] 28 -	°C
stopping temperature	42	[25 ~ 50]	°C

## 5. Display screen

### 5.1. Display interface

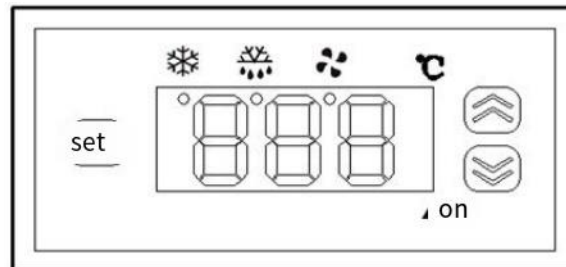

NO.	Icon	Function	Function explanation
1		Refrigerating running	Indicate whether refrigerating runs or not
2		Heater running	Indicate whether heater runs or not
3		Fan running	Indicate whether fan runs or not
4		Set key	Select function and enter parameter set
5		Up key	Increase value, page up
6		Down key	Decrease value, page down

### 5.2. Menu structures

Pressing will , and in turn the main interface if

pressing a . Wait 5 seconds and the main screen will be displayed.

**-P:** parameter setting. In the interface, press to the password input interface, and after that the password is entered correctly, it will display the parameter code, the default is P01.

Press to adj the addition and subtraction of the parameter code. After the selection of

the parameters of the code, press to , and then enter the parameters interface, and



Press and to adjust the addition and subtraction of the parameters value. And then press

to confirm the parameter values changes.

**C-P:** Check the parameters. Pressing or, will s T01, T02, T03, T04 in turn, and

the parameters can be shown several seconds later.

: Show EAA alarms. Fault alarm code will be shown in the display screen. They will be shown successively, if there are several alarms one time.

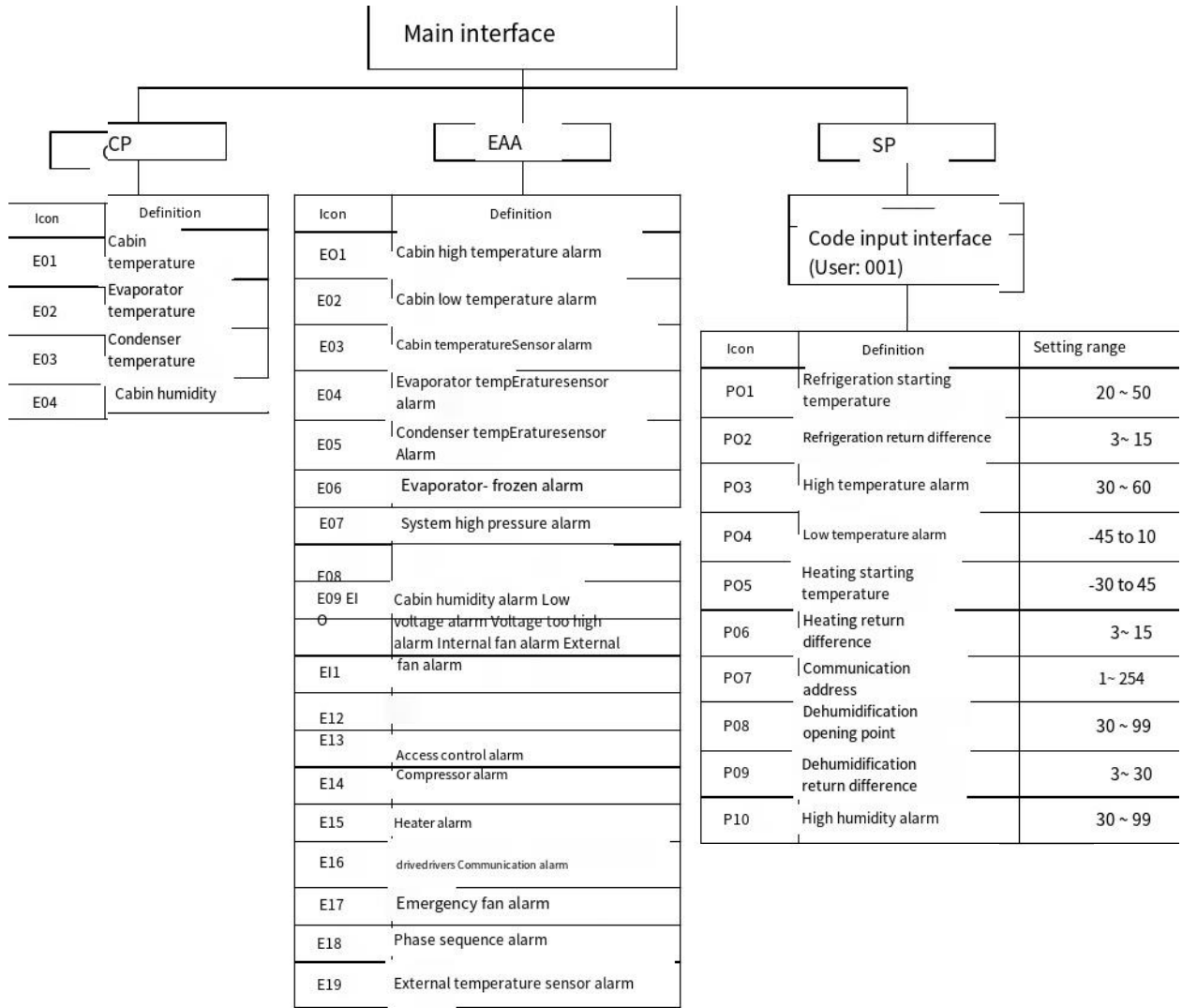

### 5.3. Display

Under running, the main interface 8.8.8 displays real temperature value in cabin  
 After boot, in any interface, if there has no keyboard operation in the continuous 20s, automatically return to the main interface

### 5.4. Start self-test

In the running states, the self-checking function can be activated by continuous pressing for **SET** seconds.  
 When Self-check, the screen will be full display for 1S, and then will normally display cabin temperature, while the boot icon will blink.

---

## 6. Running

### 6.1. Check before start running

- 1) There are not obvious blockages near the internal cycle air inlet and outlet of the air conditioner.
- 2) The input power cables and other signal cables have been connected reliably and correctly.
- 3) The input voltage and frequency should meet the requirement of air conditioner.
- 4) The fans can turn freely without abnormal noise

### 6.2. Start running

- 1) Close the input power switch, it enters the compressor protection function, and the internal cycle fan of the air conditioner will be started. After 3 minutes, If the internal cycle temperature meets the running condition, the cooling system will be started.
- 2) Operating parameters have the default settings, and it is Ok to confirm normal after running; if you need to change the parameters, please refer to the 5th section.

## 7. Faults and treatment

### 7.1. Alarm information

Item	Alarm conditions	Reset	output from dry contact
High temperature alarm	Temperature inside the cabin is higher than the setting	Automatic	Yes
Low temperature alarm	Temperature inside the cabin is lower than the setting	Automatic	No
T1 temperature sensor alarm	There is short or open circuit on the cabin internal temperature sensor cable	Automatic	Yes
T2 temperature sensor alarm	There is short or open circuit on the Evaporator temperature sensor cable	Automatic	No
T3 temperature sensor alarm	There is short or open circuit on the Condenser temperature sensor cable	Automatic	No

Evaporator-frozen alarm	Evaporator temperature is lower than 0C	Automatic	No
Frequent high system pressure alarm	System pressure is higher frequently than the setting	Automatic	No
Controller power failure alarm	No power is be input for controller	Automatic	Yes

## 7.2. Faults and treatment

Item	Possible reasons	Fault handling
Temp. sensor failures	The sensor has not been connected correctly The condenser or evaporator is dirty and blocked	Check the circuit connectors, and connect it again
	The sensor is damaged	Change the sensor
high Temperature alarm		Clean the condenser or evaporator
	Refrigerating capacity isn't enough	Please consult usability professional
	The temperature setting is fault	Set the temperature again
system pressure alarm Frequent high	The condenser or evaporator is dirty and blocked	Clean the condenser or evaporator
	External fan is fault	Change the fan
	Condenser temperature sensor wrongly sends alarm	Change the condenser temperature sensor
Evaporator-frozen alarm	Internal cycling path is blocked	Check if there are block to stick the internal cycling path
	Internal fan is fault	Maintain or change it
	Refrigerating system can't stop	Check if the air-conditioner reaches the refrigeration stop conditions but the actual status doesn't stop, if yes, inform the AC maker to deal with it.
	Evaporator temperature sensor wrongly sends alarm	Change the evaporator temperature sensor
Compressor can't run	There is no cooling demand	Check if refrigeration is not needed
	Within shutdown delay	Check if compressor is protected
	Compressor line has not been connected correctly	Check the compressor line, and connect it again
	Check if compressor protect switch is ok, and Compressor protect switch or motor is fault	change compressor protect switch if fault; if motor is fault, change the compressor

Internal fan can't run	Internal fan is fault	Change the fan
	Internal fan line has not been connected correctly	Check the Internal fan line, and connect it again
	External fan is stuck	Check if there are block to stick the fan or not, and clear the block
External fan can't run	External fan is fault	Change the external fan
	The operating condition has not been satisfied	Check if the operating condition is satisfied
	External fan line has not been connected correctly	Check the external fan line, and connect it again
	External fan is stuck	Check if there are block to stick the fan, and clear the block
Fan makes abnormal noise	Fan blades are damaged or the bearing of fan wears	Change the damaged fan
	The blades of fan scratch other objects	Check and fix it again
Heater can't run	The heater is fault	Change the heater
	The heater lines has not been connected correctly	Check the external fan line, and connect it again
	The operating condition has not been satisfied	Check if the operating condition is satisfied

## 8. Maintenance

Maintaining air conditioner very closely can keep it having a good performance and normal life, the following works should be done:

No.	Check/Maintain	Cycle
1	Check whether there are alarm information or not	6 months
2	Check whether fans can rotate normally or not	6 months
3	Check whether compressor can rotate normally or not	6 months
4	Check whether there is obvious noise or shake or not	6 months
5	Clean the inner and outer circulation air inlet and outlet of the air conditioner	6 months
6	Clean heat exchangers	1year
7	Check whether air conditioner power supply wire and communication wire is Ok or not	1year

